

Customer-Owned Gas Insulated Switchgear (GIS)

Distribution Company Awareness

This bulletin has been revised to inform Electrical Distributors of the updated requirements published in Bulletin 36-15-* under the Ontario Electrical Safety Code (OESC) for **customer-owned** padmounted Gas Insulated Switchgear (GIS), when customers connect to the Electrical Distributor's system. Below are excerpts from the bulletin.

GIS built to IEEE and IEC product standards have traditionally been used by Electrical Distributors, and are recently being specified for customer-owned high voltage service entrance installations. For example, customer-owned GIS can be used as part of the Electrical Distributor's underground distribution loop system as shown in Figure B4.

ESA has identified that the equipment does not meet the high voltage service entrance requirements of CSA C22.2 No. 31 and OESC Rule 36-204. In addition, certain configurations of GIS may include a grounding switch that has a potential of unintentionally grounding the Electrical Distributor's service conductors.

As of May 1, 2025, ESA will **no longer** accept customer-owned GIS equipment that is not approved for service entrance. ESA will only consider accepting under a deviation request when the customer provides documented proof of pending certification indicating timeline for completion of the certification under specific criteria, which the following affect Electrical Distributors:

- Enclosure to have lockable separate compartments for:
 - Supply authority switching;
 - Supply authority cables; and
 - Main consumer switch;
- Compartments containing the cables and switch for supply authority use shall be locked by the supply authority and labelled "COMPARTMENT FOR SUPPLY AUTHORITY USE ONLY";
- Switches capable of grounding the service conductors shall be made incapable of being placed in the grounded position (Figure B2), unless locked in a separate compartment under the control of the supply authority (Figure B1) ; and
- The main consumer switch shall remain readily accessible (not locked by the supply authority)

The following Figures B1 – B4 illustrate requirements for the possible configurations of customer owned GIS, used as service entrance equipment.

Figure B1: 2 Way GIS with first switch under the control of the Supply Authority

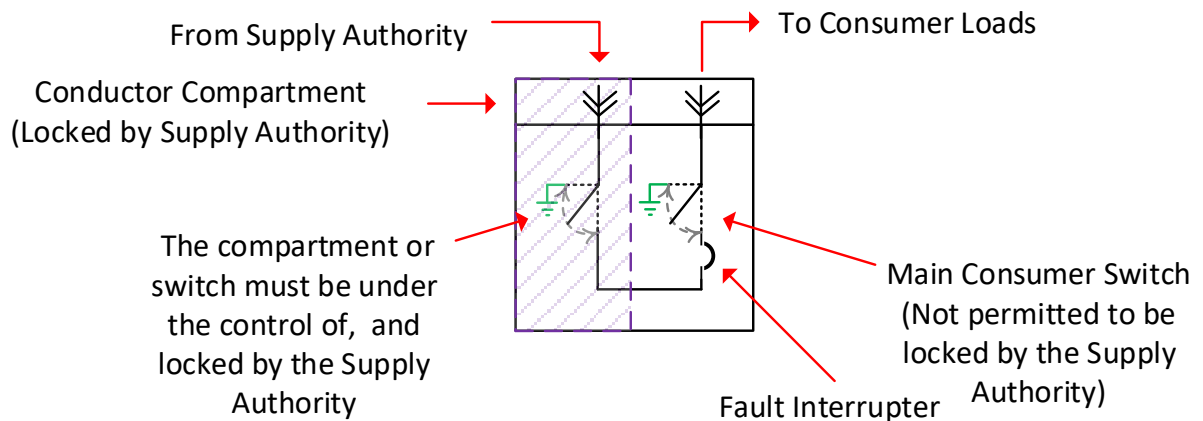

Figure B2: 2 Way GIS with first switch not under the control of the Supply Authority

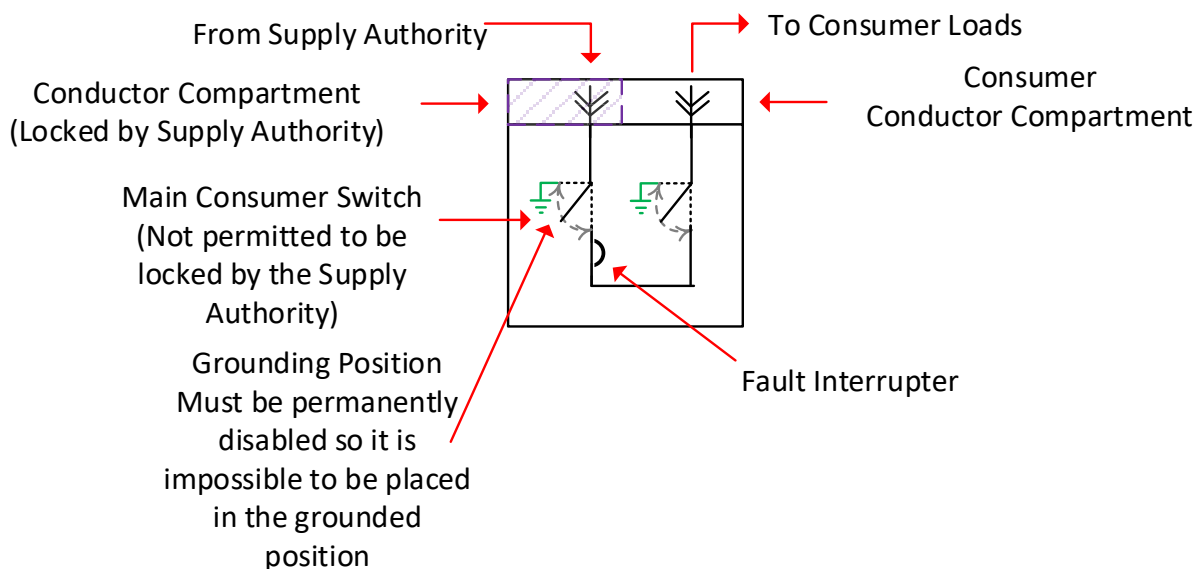

Figure B3: 2 Way GIS with single main consumer switch

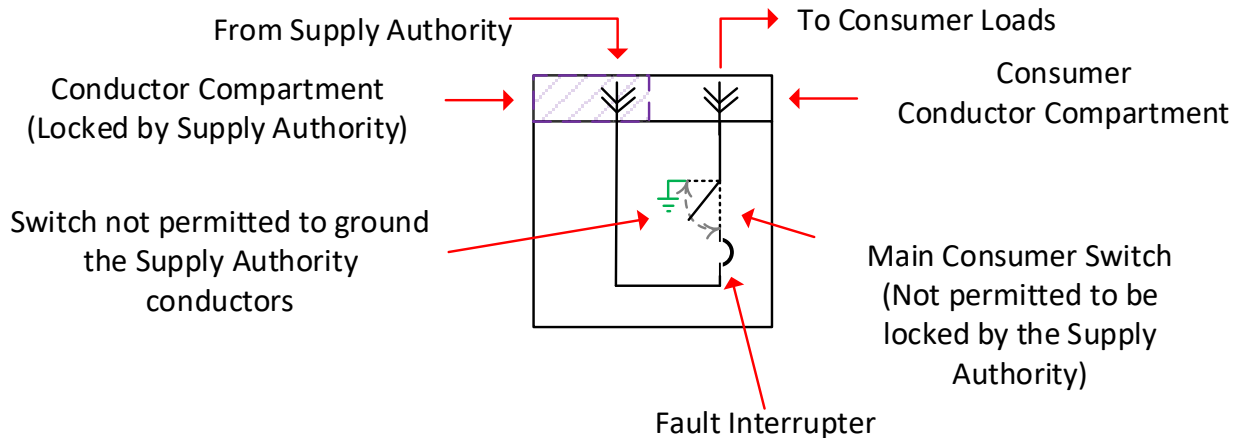
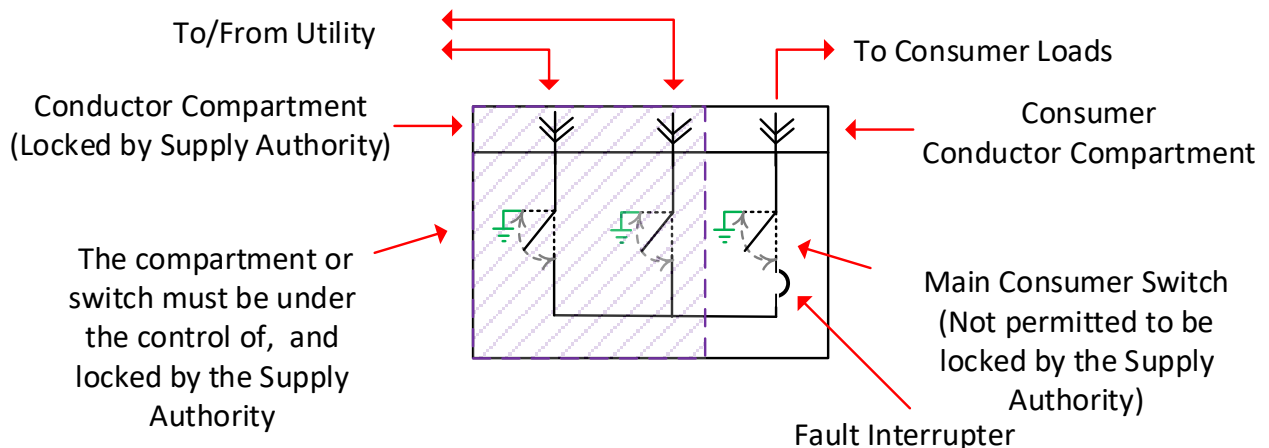

Figure B4: Supply Authority Distribution Loop/Dual Radial Feed



ESA Recommends

- Electrical Distributors should inform design and operations staff on the requirements and scenarios to apply the locks when customer installs a GIS as part of their design for service entrance application, which may include Electrical Distributor's underground distribution loop system.