



ESA Program for Acceptance of Retrofitted Luminaires Guide

Effective November 25, 2014
Updated October 13, 2016
Updated April 1, 2020

Contents

1. Introduction	3
2. Scope	3
3. Definitions	3
4. ESA Program for Acceptance of Retrofitted Luminaires Overview	4
4.1. Additional Pre-assessment Requirements	6
4.1.1. Additional Requirements for Projects with More than 50 Luminaires.....	7
4.1.2. Optional Consultations for Complex Retrofit Projects	7
4.2. Retrofitted Luminaires	8
4.2.1. Luminaires Retrofitted With an Approved Retrofit Kit	8
4.2.2. Luminaires Retrofitted Without Approved Kits	9
4.2.3. Luminaires Retrofitted with Self-ballasted Lamps.....	9
5. Appendices	11
5.1. Appendix A: ESA Program for Acceptance of Retrofitted Luminaires	11
5.2. Appendix B: Retrofitted Luminaire Notification	12
5.3. Appendix C: Retrofit kits installed in luminaires with shunted bi-pin lampholders	
13	

1. Introduction

Energy efficiency awareness and legislation are driving an increased number of luminaire retrofits and field conversions to more energy efficient sources of lighting. When any approved electrical product is modified, that product is no longer approved. This applies to luminaires or roadway lighting which is converted for energy efficiency or other purposes, by the replacement of various internal components.

Approval of electrical equipment is a safety requirement mandated by the Ontario Electrical Safety Code (OESC) to ensure that the equipment is safe for use. Equipment is approved when it bears an approval mark by an accredited certification agency or a field evaluation agency.

In addition to the standard process of approval by an accredited certification agency or field evaluation agency, in Ontario, an electrical product is deemed to be approved where the Electrical Safety Authority (ESA) determines that the product presents no undue hazards to person or property and the installation passes inspection. To deem equipment approved, ESA can request documentation, test reports, etc.

Based on the requirements of the Ontario Electrical Safety Code, Rule 2-106 5): “When installed electrical equipment is retrofitted with a retrofit kit and the installation conforms to the requirements of the Electrical Safety Authority, the equipment is deemed to be approved.” ESA has developed a program for the inspection of retrofitted luminaires.

2. Scope

This guide covers the program for acceptance of retrofitted luminaires in Ontario.

3. Definitions

Field Certification: provides a one-time certification for a specific number of product units, on-site. For every installation site, at least one product of each type has to be submitted to a recognized certification agency for certification. The product is deemed approved in accordance with OESC Rule 2-024 1) and Regulation 438/07.

Note: Certification requirements for retrofit kits are specified in CSA standard C22.2 No. 250.1 *Retrofit Kits for Luminaire Conversion*.

Field Evaluation: provides a one-time evaluation for a specific number of product units, where each unit is evaluated on-site. The product is deemed approved in accordance with OESC Rule 2-024 1) and Regulation 438/07.

Retrofit kit: A general term for a complete subassembly of parts and devices for field conversion of utilization equipment.

Approved Retrofit Kit: A kit certified to applicable Canadian standards by an accredited certification agency.

Retrofitted luminaire: A luminaire that is being modified or altered from its original approved configuration with a retrofit assembly. The process of retrofitting may also involve relocation, removal or replacement of luminaire components such as lampholders, reflectors and ballasts/power supply. A luminaire is not considered to be retrofitted when the only change is a lamp replacement.

4. ESA Program for Acceptance of Retrofitted Luminaires Overview

The Program Covers

This program covers the following types of retrofits:

- “Retrofit Type a” - T12 to T8 Fluorescent ballast replacements ONLY (the same number of lamps as before, NO new reflectors, NO new sockets or end plates)
- “Retrofit Type b” - T12 to T8 Fluorescent Luminaires (including ballast replacement, new reflectors, sockets and/or end plates)
- “Retrofit Type c” - T12 or T8 to T5 Fluorescent Luminaires
- “Retrofit Type d” - Incandescent luminaires retrofitted to LED
- “Retrofit Type e” - Fluorescent luminaires retrofitted to LED
- “Retrofit Type f” - HID luminaires retrofitted to LED
- “Retrofit Type g” - LED Retrofits for Commercial Refrigerators or freezers
- “Retrofit Type h” - LED retrofits for Roadway or Post-Top Luminaires

The Program Does Not Cover

This program does not cover retrofits in hazardous locations. Approved retrofit kits are not available for luminaires approved for hazardous locations. Field certification or the complete replacement of luminaires shall be required, where existing luminaires are installed in a classified location, and are required by Section 18, 20 or 22 of the Ontario Electrical Safety Code to be approved for hazardous locations.

This program does not cover lamps that are intended to replace existing lamps without any modification, rewiring, or component replacement in the luminaire. An example is fluorescent TLED lamp, referenced as “Type A” in CSA standard C22.2 No. 1993, that is a direct substitution of a fluorescent lamp. For lamp replacements, a Notification is not required.

The program does not cover “like for like” ballast replacements. A regular Notification of work is required.

The complete replacement of a luminaire is considered to be a wiring installation and is not addressed in this program, e.g. complete replacement of metal halide high bay luminaires with energy efficient fluorescent luminaires. A regular Notification of work is required.

Who is eligible to participate in the ESA program?

- A Licensed Electrical Contractor (LEC) authorized under *Regulation 570/05*;
- An employee or agent of the original equipment manufacturer who has been trained by the manufacturer to perform maintenance, service or repair on the equipment;
- An owner, an operator or an employee of the owner or operator in an industrial establishment or on a farm; or
- An owner or occupant of the dwelling

How the Program Works

Notification of work (Retrofitted Luminaire Notification) is required for each luminaire retrofit project site.

When a luminaire is retrofitted, a luminaire is no longer approved. In order to determine that a retrofitted luminaire does not present hazards to persons or property, ESA is introducing a pre-assessment process.

The Program will accept retrofitted luminaires as part of an ESA inspection **if**:

- an approved retrofit kit is used; and
- the pre-assessment process is completed.

The diagram below illustrates ESA's program for retrofitted luminaires:

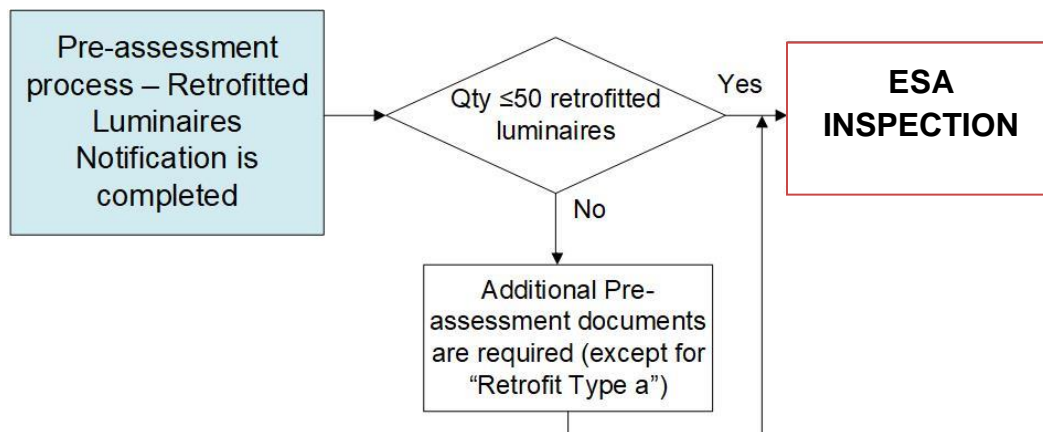

A more detailed version of the diagram is shown in **Appendix A**.

The pre-assessment process begins with the completion of the Retrofitted Luminaires Notification form (**See Appendix B**). The form has been developed to help installers determine if the selected retrofit kit is suitable for the luminaire to be retrofitted and to provide critical information to ESA in reviewing the retrofit project.

The Retrofitted Luminaires Notification form must be completed for each retrofit project, preferably before the luminaire retrofit project is started or within 48 hours of commencing the work as per Rule 2-004 1) of the OESC.

The notification form** is posted on ESA's website at:

<https://esasafe.com/fees-and-forms/forms/>

Note(**): The current form is dated October 2020.

It must be completed and emailed, faxed or mailed to ESA.

Email: esa.cambridge@electricalsafety.on.ca

FAX: 1-800-667-4278

Mail: 400 Sheldon Dr, Unit 1, Cambridge ON N1T 2H9

NOTE 1: This notification form cannot be submitted over the phone or online.

NOTE 2: If the notification form is not completed in full, it will be returned to the applicant; a wiring notification will not be created until the form is completed in full and resubmitted.

For retrofit projects with more than 50 luminaires per site, the following additional documentation is required to be submitted to ESA at the time of notification for review:

- Specification sheets for all types of retrofit kits or devices that will be installed;
- Installation instructions for each type of kit; and
- Data confirming Canadian approval of the kit (i.e. copy of the certification record or Certification Control number).

After completing the Retrofitted Luminaires Notification form (and submitting the additional documentation, if necessary), the inspection will follow.

As part of the ESA inspection and samples review, it will be verified that:

- the retrofit kit has been installed in accordance with the installation instructions and has been installed so as to not affect the mechanical integrity of the luminaire; and
- the marking and warning labels are installed in appropriate locations. For self-ballasted lamps, it is very important to verify that markings regarding replacement lamps are installed.

NOTE: If an approved retrofit kit is NOT utilized, the retrofitted luminaire is required to be re-approved by field evaluation or certification (see item 4.2.2).

4.1. Additional Pre-assessment Requirements

This section describes the pre-assessment process in detail, where retrofits have been performed under the following scenarios:

- Projects with More than 50 Luminaires (Additional Requirements)
- Optional Consultations for Complex Retrofit Projects

4.1.1. Additional Requirements for Projects with More than 50 Luminaires

For retrofit projects with more than 50 luminaires per site, the Retrofitted Luminaires Notification form and the following additional documentation (for all retrofit types specified in the Form, except “Retrofit type a”) are required to be submitted to ESA for review:

- Specification sheets for all types of retrofit kits or devices that will be installed;
- Installation instructions for each type of kit; and
- Data confirming Canadian approval of the kit (i.e. copy of the certification record or Certification Control number).

These documents are required to be provided to ESA by email, fax or mail and should be cross referenced in the notification form by checking the appropriate boxes.

Email: esa.cambridge@electricalsafety.on.ca

FAX: 1-800-667-4278

Mail: 400 Sheldon Dr, Unit 1, Cambridge ON N1T 2H9

ESA will not be able to proceed with the pre-assessment until all required information is provided. A wiring notification will not be released to the Inspector until the proper evaluation of pre-assessment documents is completed.

If the retrofit kit is not approved, ESA will notify the applicant that field approval is required (See item [4.2.2](#)).

The ESA pre-assessment does not relieve the applicant from the responsibility to comply with the Ontario Electrical Safety Code requirements for all aspects of the project.

4.1.2. Optional Consultations for Complex Retrofit Projects

For large retrofit projects involving several different types of luminaires to be retrofitted, in addition to the pre-assessment, you may consult with an ESA Inspector.

- Consultations should be performed before any work has started and after the ESA pre-assessment has been completed.
- All relevant information specific to the retrofit project, including the pre-assessment recommendations, should be made available to the Inspector at the on-site consultation.

4.2. Retrofitted Luminaires

This section describes luminaires retrofitted with kits that are designed and approved for these luminaires and issues that may arise when luminaires are retrofitted without using approved retrofit kits. The following types of retrofitted luminaires are explained:

- Luminaires Retrofitted **with** an Approved Retrofit Kit
- Luminaires Retrofitted **without** an Approved Retrofit Kit
- Luminaires Retrofitted with Self-ballasted Lamps

4.2.1. Luminaires Retrofitted With an Approved Retrofit Kit

Installation of the approved retrofit kit into the intended luminaire facilitates continued compliance of the retrofitted luminaire with the requirements of the applicable product safety standards when:

- components and materials provided with the kit are used; and
- the kit is installed in accordance with the installation instructions.

An approved retrofit kit is equipped with appropriate warning labels. The installation of the proper warning labels on retrofitted luminaires is critical for safe “after conversion” maintenance.

The changing of lamp types (from LED back to fluorescent) in luminaires may present hazards for anyone doing maintenance after the conversion. Lamps shall be replaced “like for like” to ensure electrical safety and avoid compromising the luminaire certification.

LED retrofit kits that reuse existing lampholders or otherwise permit the insertion of previously used lamps, shall have the following marking (or similar) applied to the retrofitted luminaire, in a location where it is visible during relamping.

“This luminaire has been modified to operate LED lamps. Do not attempt to install or operate _____* lamps in this luminaire.”

“*” shall be replaced by the original lamp type, such as, “fluorescent,” “HID,” etc.

Also, LED retrofit kits that involve replaceable lamps shall include the following marking applied to the retrofitted luminaire where visible during relamping.

REPLACE ONLY WITH
[Manufacturer][Catalogue Number]
_____*

“*” shall be replaced with: LED Lamp or LED driver, as applicable. See the example of an appropriate Warning label supplied by a manufacturer:

This luminaire has been modified and no longer operates fluorescent lamps.
Use only XXXXXX LED Tube lamps for lamp replacement.

NOTE: In tubular fluorescent luminaires employing shunted bi-pin lampholders, DO NOT install retrofit kits where the installation instructions specify that the power supply be connected to the same lampholder. For more information, see **Appendix C**.

Different types of retrofits require different markings. For the safety of the maintenance personnel, it is critical to apply the appropriate warning labels to the retrofitted luminaires.

If a retrofit kit is not suitable for the existing luminaire, there may be safety issues. For example, when a reflector is not appropriate, there may be gaps between the reflector and the luminaire case resulting in exposed wires and terminals at the ballast end, which could present a shock hazard.

4.2.2. Luminaires Retrofitted Without Approved Kits

If an approved retrofit kit is not used, all retrofitted luminaires are required to be re-approved. There are two options for re-approval: field evaluation or field certification. The installer must contact one of the recognized field evaluation agencies for the field evaluation or a recognized field certification agency for the field certification of the retrofitted luminaires. Installers who have used retrofit kits that are not approved are advised to apply for field approval of retrofitted luminaires before submitting the Retrofitted Luminaires Application for Inspection.

For the list of the recognized certification or field evaluation agencies, visit the “Electrical Products” section of www.esasafe.com.

When field evaluation is required for luminaire retrofit projects with more than 500 retrofitted luminaires, the contractor is advised to contact ESA to apply for a deviation. In Ontario, field evaluation is limited to 500 units of electrical equipment, of the same model, per year; therefore if necessary, a deviation is required to exceed that number. For a deviation request, contact your local ESA Inspector.

4.2.3. Luminaires Retrofitted with Self-ballasted Lamps

If an approved retrofit kit is not used, but an approved self-ballasted lamp is utilized and the only modification of the existing luminaire is disconnection of the existing ballast and rewiring of the power supply to the existing lampholders, one sample of the retrofitted luminaire needs to be field evaluated. The remainder of the luminaires are required to be retrofitted and marked the same way.

The remainder of the retrofitted luminaires will be deemed approved if the installation passes ESA inspection.

5. Appendices

Appendix A: ESA Program for Acceptance of Retrofitted Luminaires

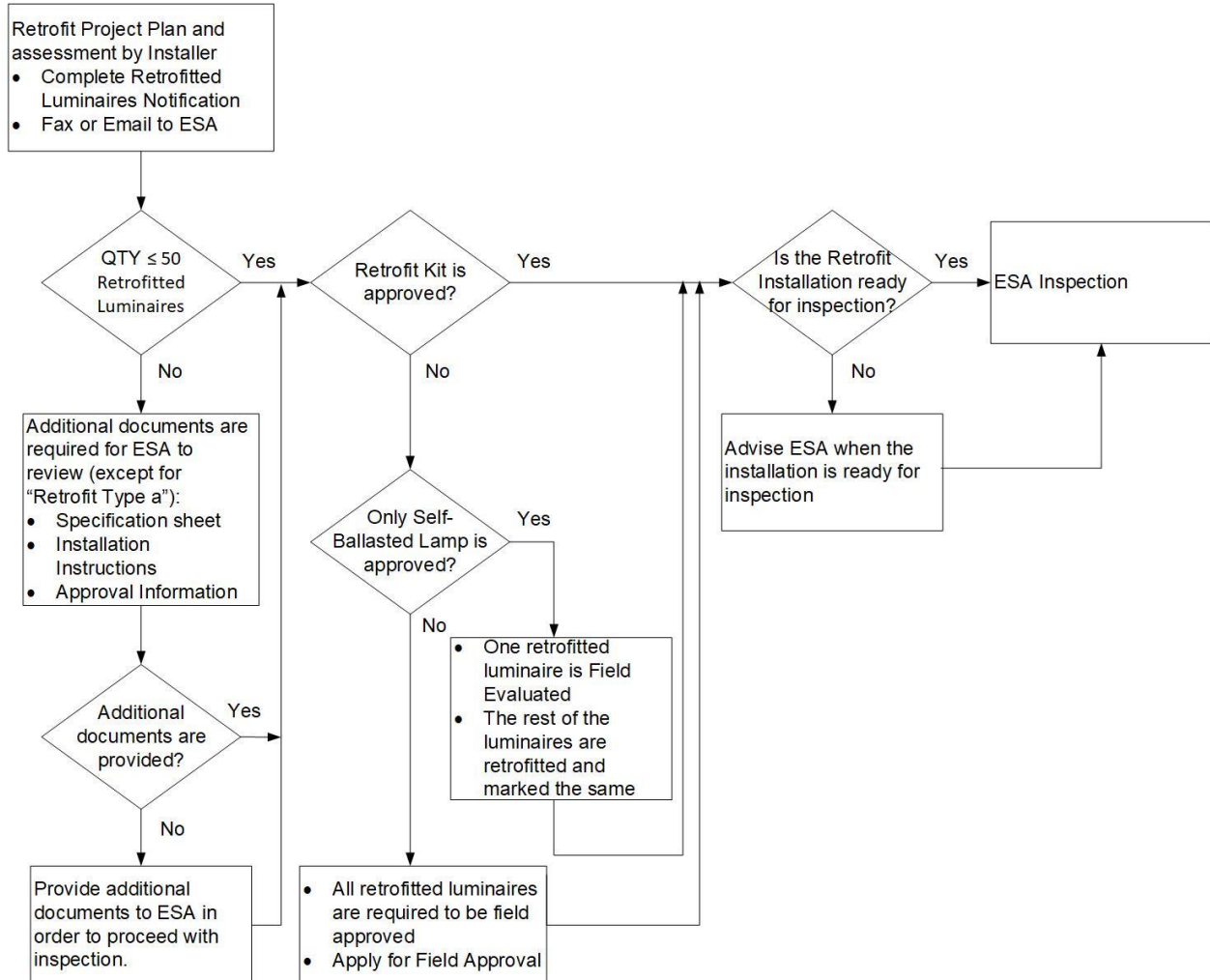

Appendix B: Retrofitted Luminaires Notification



ESA Program for Acceptance of Retrofitted Luminaires Notification

A Notification is required for each Project Site with retrofitted luminaires. All other electrical work not part of this program, including luminaire replacement, must be submitted on a separate Notification & Fee Estimate. For information on the Program for Acceptance of Retrofitted Luminaires, see the technical guideline posted at: <http://www.esasafe.com/business/retrofitted-luminaires>

When a luminaire is retrofitted, it is no longer approved. A retrofitted luminaire is acceptable to ESA when a suitable, approved retrofit kit is used, installed in accordance with installation instructions, and passes ESA inspection. A field evaluation or field certification will be required on all retrofitted luminaires if a retrofit installation is completed using only approved parts, or an approved retrofit kit that has been modified or altered to fit into the existing luminaire.

To determine if the retrofitted luminaire is compliant to safety standard requirements and can be accepted by ESA, the Notification and supporting documentation are reviewed. The pre-assessment process begins with completing a Retrofitted Luminaires Notification.

The Notification must be submitted by the installer of the luminaire retrofit. Please follow the checklist below to ensure the Notification to be submitted is complete. *Notifications with missing or incorrect information will be returned to the applicant*

Notification Checklist:

- Read: [ESA Program for Acceptance of Retrofitted Luminaires Guide](#) to confirm the retrofit installation is part of the program. (i.e. lamp for lamp replacement or a complete luminaire replacement are not part of the Retrofitted Luminaires Program).
- "Applicant Information" section is complete
- "Site Information" section is complete, including site contact name and telephone number.
- "Ready For" section is complete.
- "Retrofit Project Details" - All Applicable information is provided for each style of luminaire retrofitted
NOTE: Select "Retrofit Type a" for T12 to T8 fluorescent ballast replacements ONLY, where there is NO change in the number of installed lamps and no new reflectors, new sockets or new end plates installed. If other changes are made select "Retrofit type b" and provide the required details.
- "Retrofit kit Installation" section is complete for ALL retrofit types, EXCEPT "Retrofit Type a"; all three questions answered, including any additional comments.
- "Declaration" section is complete and signed by the retrofit installer

For all retrofit types with quantity greater than 50, EXCEPT "Retrofit Type a"; supply the following information:

- Specification sheet(s) for all retrofit kit/ components being installed
- Installation instructions for all retrofit kit/ components being installed
- Certification Agency file number (i.e. CSA, cUL, cETL, etc.), or Field Evaluation approval confirmation



400 Sheldon Dr, Unit 1
Cambridge, Ontario N1T 2H9

Phone: 1-877-ESA-SAFE (372-7233)
Fax: 1-800-667-4278
Email: esa.cambridge@electricalsafety.on.ca

Retrofitted Luminaires Notification

Account #:		ECRA/ESA Lic #:		ACP #:		Date:	
<input type="checkbox"/> Charge to ESA Account <input type="checkbox"/> Cheque / Money Order		Payment Method <input type="checkbox"/> Credit Card ESA account customer - provide the last 4 digits of the card saved on file with ESA _____ <input type="checkbox"/> One-time / non-account customer - submit the completed application and an ESA representative will call to process the credit card payment.				Ready for: <input type="checkbox"/> Will Notify <input type="checkbox"/> Rough In <input type="checkbox"/> Final Ready date: _____	
Applicant / Installer Information (mailing address) Name: _____ Address: _____ Unit/Store: _____ City: _____ Prov/State: _____ Country: _____ Postal Code: _____ Phone: _____ Fax: _____ Email: _____							
Site Information Site Type: <input type="checkbox"/> Commercial <input type="checkbox"/> Industrial <input type="checkbox"/> Agricultural <input type="checkbox"/> Street Lighting <input type="checkbox"/> Apartments <input type="checkbox"/> Residential Total Fixture Quantity: _____ Site Name: _____ Civic #: _____ Street: _____ <small>(if street is a #0 Regional Rd, County Rd, Hwy - note the alternate street name (if appl):)</small> City/Town: _____ Twp/Region: _____							
Main Intersection: _____ Water Travel Required? Yes <input type="checkbox"/> No <input type="checkbox"/> Work Contact Name: _____ Phone: _____ Email: _____							
Retrofit Project Details Retrofit Type: a T12 to T8 Fluorescent BALLAST REPLACEMENT ONLY (the same number of lamps as before, NO new reflectors, NO new sockets or end plates) City of Luminaires - "Retrofit Type a" ONLY							
Retrofit Type List		Qty of Luminaires		Voltage		Retrofit Kit Details	
						Are the existing lamp sockets used? Yes No Are self-ballasted lamp installed? Yes No Are approved retrofit kits used? Yes No	
b T12 to T8 Fluorescent Luminaires (including ballast replacement, new reflectors, sockets or end plates) c T12 or T8 to T5 Fluorescent Luminaires d Incandescent luminaires retrofitted to LED e Fluorescent luminaires retrofitted to LED f HID luminaires retrofitted to LED g LED Retrofits for Commercial Refrigerators h LED retrofits for Roadway or Post-Top Luminaires i Other (Describe in Comments section)						Manufacturer Model Number Certified By:	
Retrofit Kit Installation (for all types except "Retrofit Type a") Warning labels are provided and will be applied? Yes <input type="checkbox"/> No <input type="checkbox"/> Installation Instructions provided will be followed? Yes <input type="checkbox"/> No <input type="checkbox"/> Is retrofit kit compatible with existing luminaires? Yes <input type="checkbox"/> No <input type="checkbox"/> Total Fee Estimate: _____ Total # of pages: _____ (including Notification form)				COMMENTS: DECLARATION - TO BE COMPLETED FOR EACH NOTIFICATION: The information provided on this form is true and accurate. Installer Name (please print): _____ Date: _____ Signature: _____			

By submitting personal information to the Electrical Safety Authority, or its agents and service providers, you agree that ESA may collect, use and disclose such personal information in accordance with its privacy policy, applicable laws or pursuant to our administrative agreement with the Province of Ontario. If you provide us with the personal information on behalf of another individual, you represent that you have all necessary authority and/or have obtained all necessary consents from such individual to enable us to collect, use and disclose such personal information for the purposes set forth in our Privacy Policy. A copy of our policy is located on our website at www.esasafe.com

Appendix C: Retrofit Kits Installed in Luminaires with Shunted Bi-pin Lampholders

There are some Retrofit kits that require the power supply to be connected to only one lampholder, see Diagram 1. The high efficiency ballast, or LED driver, is an integral part of the device (fluorescent or LED tube). These retrofit kits require the lampholders to be rewired and the existing fluorescent ballast to be bypassed. The line and neutral conductors are required to be connected to the same lampholder. The other lampholder is not used for electrical connections and will only be intended for mechanical support of the lamp, as shown in Diagram 1.

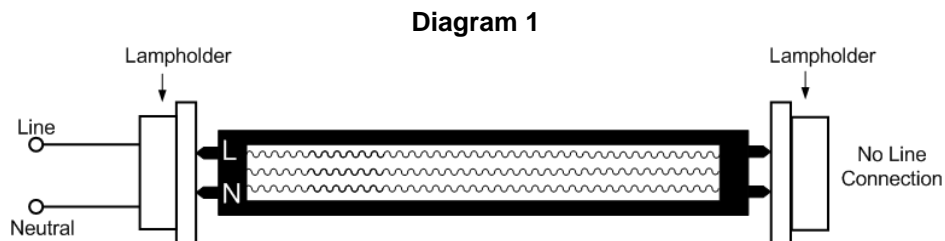

These kits may pose a potential fire or shock hazard at the time of installation when they are used in luminaires with shunted bi-pin lampholders. Shunted bi-pin lampholders have an internal short circuit (shunt) between the lampholder contacts, see Photo below.

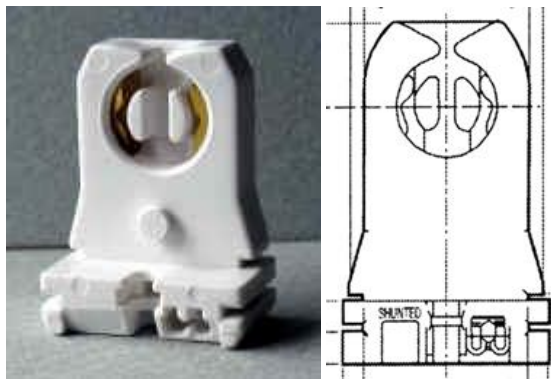

Shunted lampholders are found in the fluorescent luminaires with “instant-start” ballasts. Instant start ballasts may be marked with “Instant Start” or “I.S.” and lampholders intended for use with instant-start electronic ballasts are marked with a circled “I”.

DO NOT INSTALL TUBULAR FLUORESCENT LAMPS RETROFIT KITS (BOTH FLUORESCENT AND LED) IN LUMINAIRES EMPLOYING SHUNTED BI-PIN LAMPHOLDERS WHEN THE RETROFIT KIT INSTRUCTIONS SPECIFY THAT LINE AND NEUTRAL POWER BE CONNECTED TO THE SAME LAMPHOLDER.